

Collection Moll

12758010001 Panier porte-éponge

PRODUIT



DESSIN

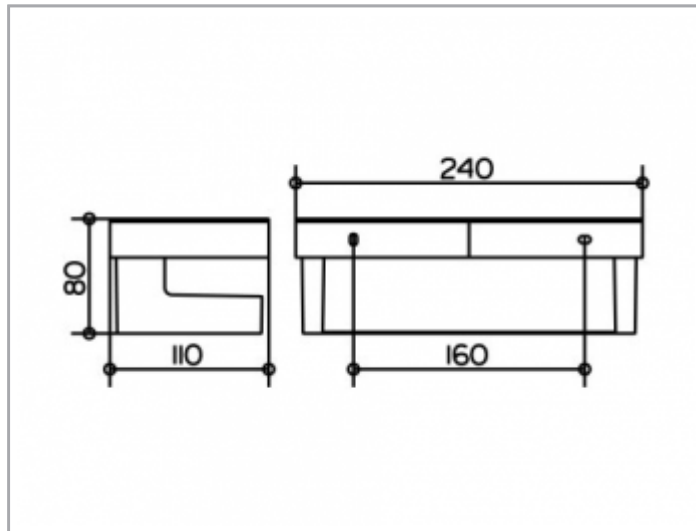

CARACTÉRISTIQUES DU PRODUIT

2 pièces: panier en métal et pièce d'insertion en synthétique amovible, incassable, résistant au savon et aux UV

SURFACE

chromé/anthracite

SPECIFICATIONS

KEUCO COLLECTION MOLL shower basket, wall mounted
12758010001

Chrome-plated metal basket with removable, soap resistant, break-proof and UV-protected, anthracite, easy to clean

Total depth 110 mm, height 80 mm, total width 240 mm

The shower basket is fitted with 2 hidden fixing points
incl. corrosion-free mounting material